

TORQUE LIMITER FREE ROTATION

(SAFETY COUPLINGS)

Up to 1.200 Nm of torque and 65 mm bore

DSS/SG/RF



ComInTec[®]
Technology for Safety

DSS/SG/RF - torque limiter free rotation: introduction



- ⦿ Absence of torsional play during the transmission of motion.
- ⦿ Fine-tuning the torque through a balanced radial ring.
- ⦿ Motion transmission through balls.
- ⦿ An innovative calibration system with "H dimension" for an immediate calibration of the equipment.
- ⦿ Manual re-engagement.
- ⦿ No residual torque after disengagement.
- ⦿ Possibility of combining a switch / proximity to stop the engine.

ON REQUEST

- ⦿ Complete transmission gear worked and fitted (crown, pulley, gear, ...).
- ⦿ Can be supplied with various types of rigid/elastic couplings for in-line shafts transmission.
- ⦿ Possibility of surface treatments for corrosion-specific needs.
- ⦿ Possibility of connection with 8 holes interchangeable with other products on the market.

A backlash free Safety coupling with free rotation and low residual torque suitable for high speed transmission. The disengagement is instantaneous once the torque is reached, the calibration is adjusted by changing the pressure of the springs. The re-engagement is manual, quick and reliable.

APPLICATIONS

- ⦿ Extruders.
- ⦿ Packing machines.
- ⦿ Automation technology.
- ⦿ Test benches.

ADVANTAGES AND BENEFITS

- ⦿ Protect the elements of a transmission even in case of high inertias.
- ⦿ Protect the product from shock or incorrect positioning.
- ⦿ Protect devices during transmission at high speeds of rotation.
- ⦿ Greater durability of all devices, thanks to the free rotation.

	.../DSS/SG/RF: version suitable for immediate release to overcome Torque calibration; low residual torque after disengagement.	from 10 to 1200 Nm 65 mm max bore	Pag. 46
	... + GAS/SG: connection with flexible coupling and locking clamp for quick installation.	from 10 to 1200 Nm 70 mm max bore	Pag. 48

ASSEMBLY EXAMPLES

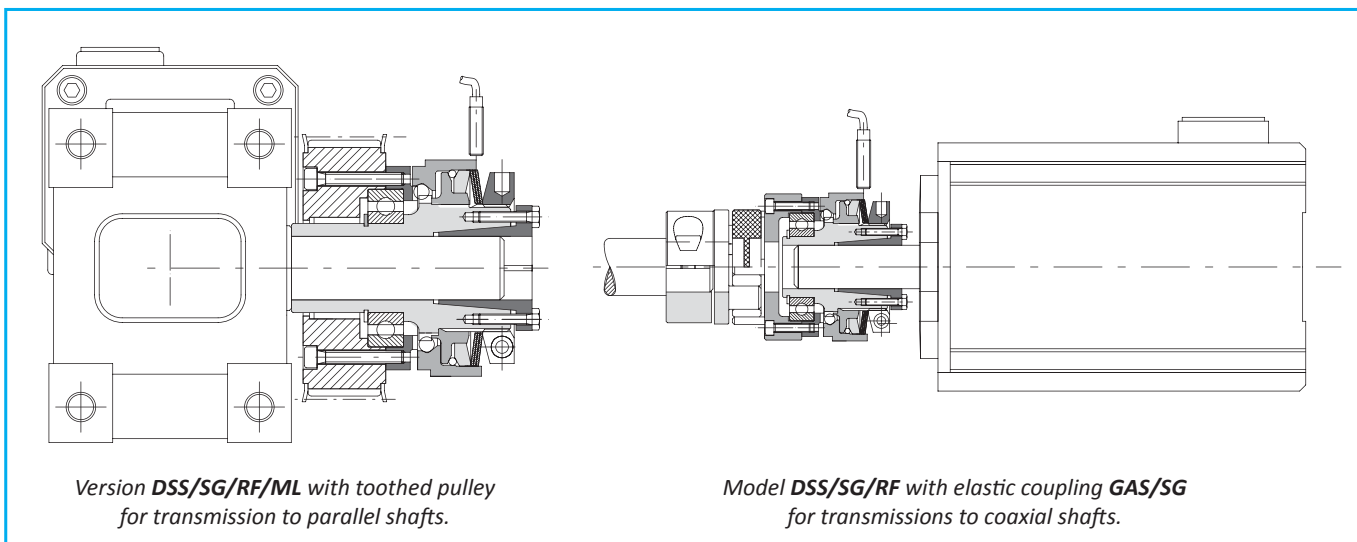

Version **DSS/SG/RF/ML** with toothed pulley for transmission to parallel shafts.

Model **DSS/SG/RF** with elastic coupling **GAS/SG** for transmissions to coaxial shafts.

OPERATION

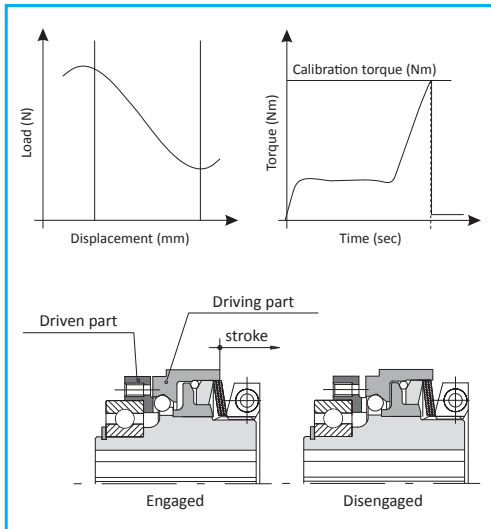

This model of torque limiter negative version to incorporate the following features:

- ⦿ Backlash free with compact dimensions
- ⦿ Instantaneous reduction of the couple at the time of overloading
- ⦿ Absence of residual torque, after disengagement
- ⦿ Immediate response times and high sensitivity

Suitable for protecting against overloads within automatic machines with significant powers and inertias and high rotation speeds. When an overload occurs an immediate and complete separation of the drive and driven occurs and will remain disconnected in free rotation until it is re-engaged manually or using a suitable tool. A possible micro switch or sensor detects the movement of the movable base by generating an electrical signal necessary to stop the transmission. This electrical signal can also be used for further control functions. Electromechanical microswitches model EM1 or EM2 or inductive sensors model PRX, available from Comintec.

TORQUE ADJUSTMENT

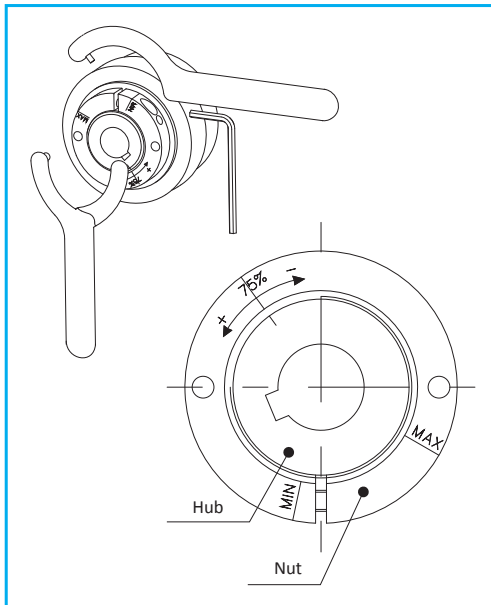

Adjustment of the Negative version is opposite to all other units in our range. Unlike the traditional units, by rotating the adjuster nut clockwise the disengagement torque will reduce, and therefore to increase the torque the nut must be rotated anti-clockwise. To assist the operator in setting, there are clear markings on the nut showing 75% of the max torque and +/- Min/Max directions indicated.

Unless otherwise requested, these models are supplied pre-calibrated at 75% of the maximum torque value of the spring's chosen configuration.

HOW TO USE AND ASSEMBLE

The device is supplied ONLY with finished bore in the hub, unless otherwise specified, with tolerance H7 and keyway according to UNI 6604 (DIN 6885-1) with tolerance H9, H7 tolerance or without keyway with integrated locking assembly.

The device can be fixed axially by a screw and washer for the version with hole and keyway or by the locking device integrated in the version without key. They can be used, on request, also conical rings. The device is NOT self-supporting so it is necessary to provide that the shafts on which it will be fitted are with bearings and are supported in the case of the application are met with coupling misalignment shown in the catalog.

MAINTENANCE

These devices, mechanical, are maintenance-free.

In the case of the torque is appropriate to take account of different variables that combined together can affect the length of the limiter:

- Torque intervention in relation to the range provided by the limiter.
- Whether the frequency and duration of interventions.
- Ability to dissipate heat generated by the sliding.
- Speed of rotation.
- Environmental working conditions.

DSS/SG/RF - torque limiter free rotation: technical data



- Simple manual re-engagement without special equipment.
- Suitable to be installed in the kinematic chains with high inertia.
- Available with extended hub for assembly of wide organs: ... / ML.
- Organ mounted and directly supported by a ball bearing.
- Model available only with finished bore (with keyway or with locking assembly).
- Torque range: 25-1200 Nm; $\phi 65$ mm maximum bore.

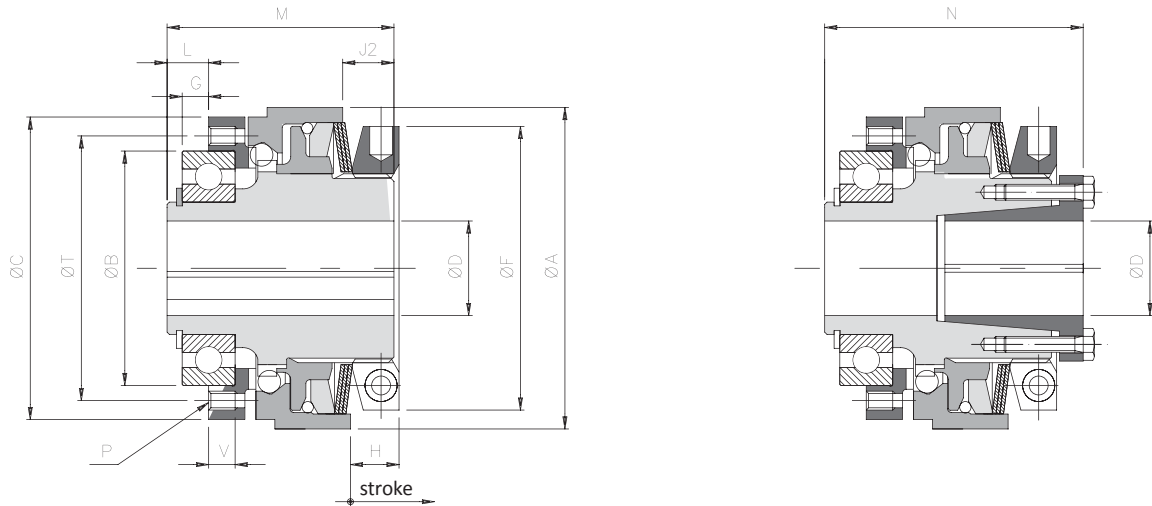

DIMENSIONS

Size	A	B h5	C	D H7	F	* G	L	J2	P	M	N	T	V	On request "8C"						
				Max.		B h5								C	G	L	P	T	V	
0.63	70	42	65	20	62	4	7	12	6xM5	50	57	48	7	47	-	5	8	8xM4	56	6
1.80	85	62	80	25	75	7	11	13,5	6xM5	60	68	70	7	-	-	-	-	8xM5	71	-
2.96	100	75	96	35*	82	9	14	16	6xM6	70	78	89	9	-	95	-	-	8xM6	85	-
3.116	115	90	115	42	97	8	14	17	6xM8	80	89	105	12	-	110	10	16	8xM6	100	10
4.138	135	100	138	50	117	6,5	14,5	20,5	6xM10	95	106	125	14	-	130	10	18	8xM8	116	11
5.172	165	130	172	65	145	11	20	33	6xM12	120	135	155	18	-	166	12	21	8xM10	150	15

TECHNICAL DETAILS

Size	Torque [Nm]				Stroke [mm]	Locking assembly		Inerzia [kgm ²]			Max speed [Rpm]	Weight [Kg]	
	T1	T2	T3	T4		Screws	Tightening torque [Nm]	Flange side	Nut side	Nut side		cava	Locking assembly
									keyway	Locking assembly			
0.63	10 - 22	20 - 30	30 - 50	-	1,8	6xM4	4,1	0,00008	0,00039	0,00040	8000	1,2	1,2
1.80	20 - 40	35 - 70	55 - 100	-	2	8xM4	4,1	0,00029	0,00115	0,00118	7000	2	2,1
2.96	40 - 70	70 - 105	100 - 150	120 - 200	2,5	10xM4	4,1	0,00068	0,00257	0,00264	6000	3,6	3,8
3.116	70 - 150	150 - 220	200 - 350	280 - 400	4	8xM5	8,5	0,00129	0,00473	0,00493	5000	5,0	5,4
4.138	150 - 280	280 - 380	350 - 550	350 - 700	4,5	8xM6	14	0,00315	0,01083	0,01132	4000	8,7	9,3
5.172	300 - 450	450 - 600	580 - 950	700 - 1200	5	8xM8	35	0,01012	0,03302	0,03380	3500	13,0	13,4

NOTES

▲ On request

- DH7*: maximum diameter for finished bore with reduced keyway according to UNI 7510.
- G*: assembly tolerance +0,1.
- Weights are relevant to the pilot bore; inertias refer to the maximum diameter for finished bore of the torque limiter.
- Microswitches EM1 or EM2 and inductive sensor PRX see page 73

... + GAS/SG - model with jaw coupling and single split clamp hub type "B": technical data

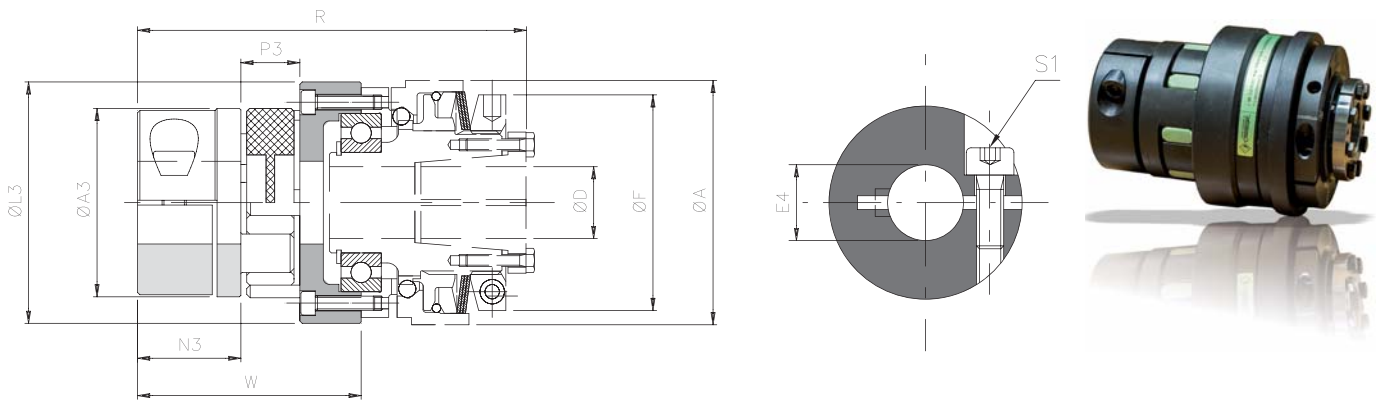

DIMENSIONS

Size		Torque [Nm]		A3	E3 H7 max	L3	N3	P3	A	D H7	F	W	R
/RF	GAS SG	Nom	Max							max			
0.63	0	60	120	55	30	65	30	18	70	20	62	63	112
1.80	1	160	320	65	35	84	35	20	85	25	75	74,5	131,5
2.96	2	325	650	80	45	102	45	24	100	35	82	93	157
3.116	3	450	900	95	50	122	50	26	115	42	97	100	175
4.138	4	525	1050	105	60	143	56	28	135	50	117	110,5	204
5.172	6	1040	2080	135	70	178	100	35	165	65	145	147	262

TECHNICAL DETAILS

Size		Clamp hub		Misalignments			Rigidity			Inertia coupling side [Kgm ²]	Max. speed [Rpm]	Weight [kg]
/RF	GAS SG	Screws	Tightening torque [Nm]	Angular α [°]	Axial X [mm]	Radial K [mm]	Torsional [Nm/rad]	Axial [mm]	Radial [mm]			
0.63	0	M6	15	0° 54'	1,4	0,10	3650	8100	2900	0,00040	8000	0,7
1.80	1	M8	36		1,5	0,11	4180	10700	3650	0,00107	7000	1,7
2.96	2	M8	36		1,8	0,12	8150	21850	5000	0,00296	6000	1,9
3.116	3	M10	70		2,0	0,15	15000	34000	5900	0,00559	5000	3,2
4.138	4	M12	121		2,1	0,16	16000	49000	6800	0,01213	4000	5,8
5.172	6	M12	121		2,6	0,18	38000	97000	6400	0,04301	3500	13

TRANSMITTABLE TORQUE WITH CLAMP HUB ASSEMBLY

Size	Transmission torque [Nm] according to the ø finished bore [mm]																							
	12	14	15	16	18	19	20	22	24	25	28	30	32	35	38	40	42	45	48	50	55	60	65	70
0 (24)	76	78	80	81	84	85	87	89	92	93	97	100												
1 (28)					165	167	170	175	179	182	189	194	199	207										
2 (38)							199	204	209	212	219	224	229	237	244	249	254	262						
3 (42)										320	330	337	343	353	363	370	376	386	396	403				
4 (48)																	1640	1677	1714	1738	1800	1861	1922	
6 (55)																		1824	1861	1885	1947	2008	2069	2130

▲ On request

NOTES

- These details refer only for the coupling (GAS/SG with backlash free red element 98 Shore-A), for torque limiters details see on page 46.
- Weights are relevant only to the pilot bore (GAS/SG); inertias refer only the coupling with maximum bore (GAS/SG).
- Microswitches EM1 or EM2 and inductive sensor PRX see page 73

DSS/SG/RF - torque limiter free rotation: additional information

OTHER COUPLING TYPES AVAILABLE ON REQUEST

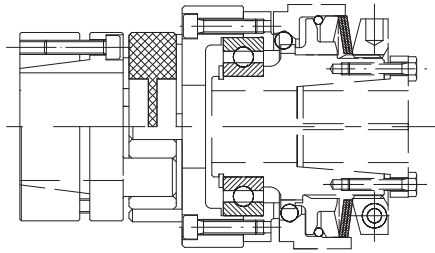

Model **DSS/SG/RF** with backlash free jaw elastic coupling
GAS/SG/CCE with integrated locking assembly when is required
 to accomodate misalignment with high torsional rigidity.

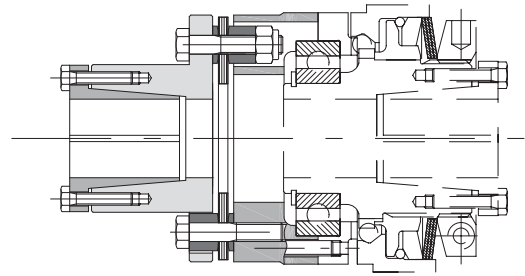

Model **DSS/SG/RF** with single flexing disc coupling **GTR/S**,
 for applications where torsional rigidity is required.

ORDER EXAMPLE

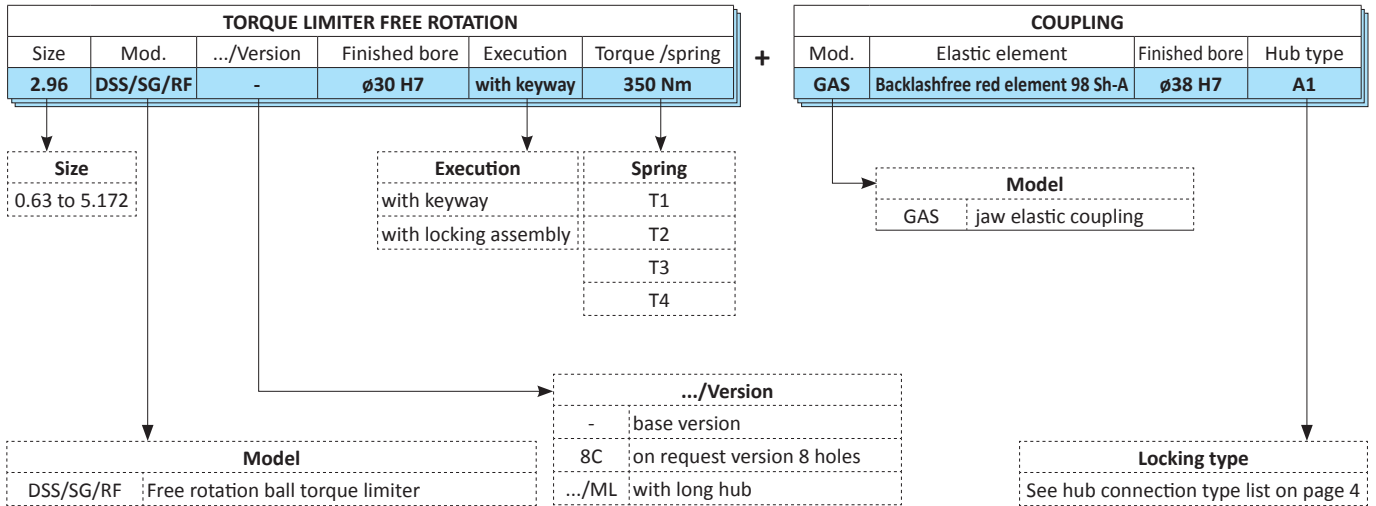

- Model available only with finished bore.