

# *Safety*

## **Parker EME Safety Technology**



ENGINEERING YOUR SUCCESS.

## Safety new Standard EN ISO 13849-1

- The actual EN 954-1 can be used until the end of 2009.

=> This was extended in late December 2009, for the next 2 years.



1st. January 2012 the EN ISO 13849-1 became mandatory.

**The new Standard has the same objective as does the  
EN 954-1:**



**„A control device must be sufficiently safe “**

## Changes to EN 954-1

- New risk graph to determine the Performance Level  $PL_r$  
- Introduction of **Performance Level (PL) a up to e.**   
The five PL (a, b, c, d, e) describe the average failure probability of the employed components per hour.
  - $MTTF_d$  = Mean time to hazardous failure of a channel
  - CCF = Assessment of failure due to common cause
  - DC = Diagnostic coverage

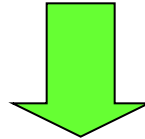

## Advantages of the new EN ISO 13849-1

The new standard has established a basis for realising safety functions with semiconductors.

# Safety

## Safety assignment for Compax3 S / H / M



## Safe Torque Off (STO)

### Compax3S:

- Certificate EN 954-1
- Certificate EN13849-1
- Generally: Category 3 PL e
  - Category 3 PL d with fieldbus
  - Category 3 PL e with fieldbus + fix I/Os ( in work)



### Additional safety function: Category 3 PL d

#### additional safety functions:

- ◆ Safe Torque Off, STO
- ◆ Safe Stop 1, SS1
- ◆ Safe Stop 2, SS2
- ◆ Safely-limited speed, SLS
- ◆ Safe operating Stop, SOS
- ◆ Safely limited increment, SLI
- ◆ Safe direction, SDI
- ◆ Safe Input/Output Signals



### Additional safety function: Category 3 PL d

- Compax3S **F11\*** + external safety control module from BBH;  
=> Type: SMX11
- no external encoder necessary! 



## Additional safety function C3S with external safety module SMX11 Category 3 PL d

Prinzipschaltbild:

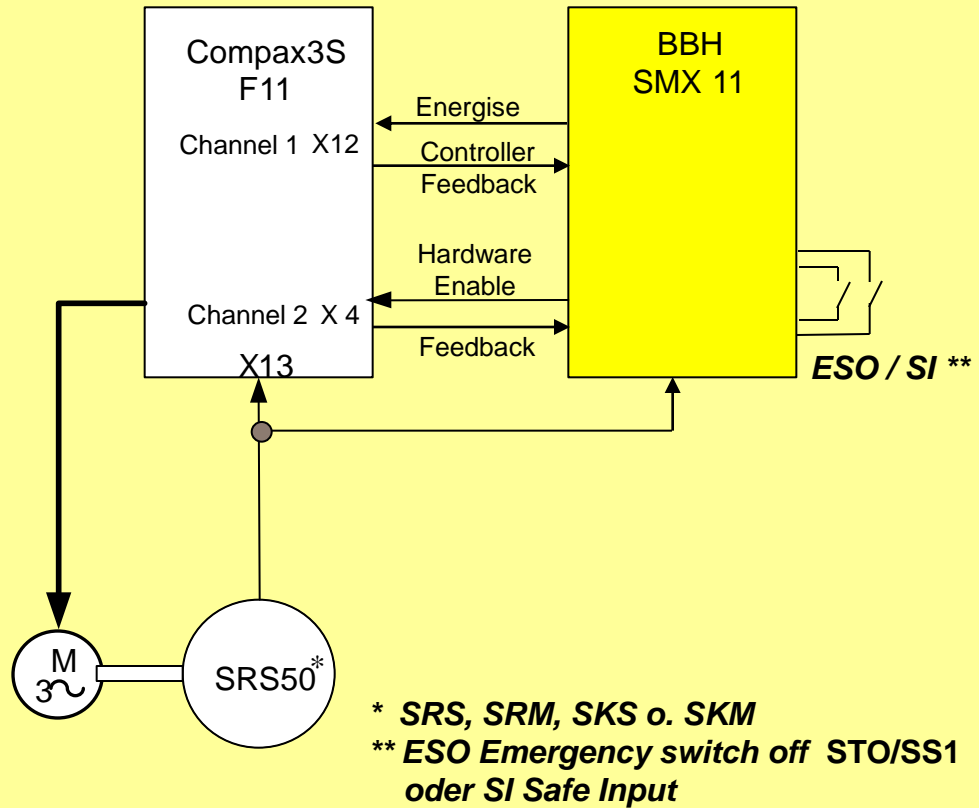

### Additional safety function: Category 4 PL e

- Compax3S + external safety module from BBH;  
=> Type: SMX12
- second external encoder necessary! 

#### additional safety functions

- ◆ Safe Stop 2, SS2
- ◆ Safely-limited speed, SLS
- ◆ Safe operating Stop, SOS
- ◆ **Safely limited position, SLP**
- ◆ Safely limited increment, SLI
- ◆ Safe direction, SDI
- ◆ Safe Input/Output Signals



## Additional safety function C3S with external safety modul SMX12

schematic diagram:

Cat. 4 PL e

or

Cat. 4 PL e

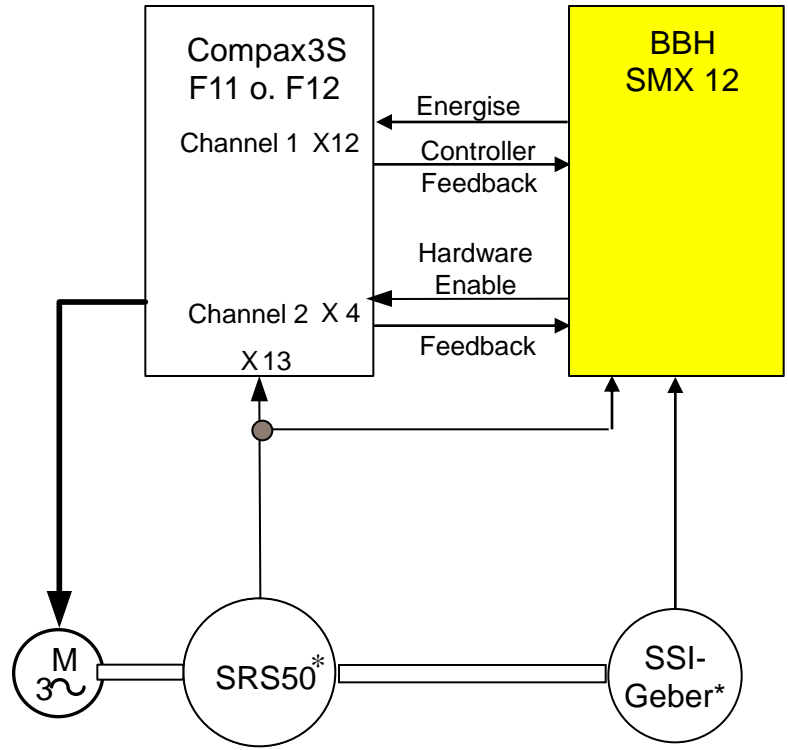

\*or TTL-Encoder

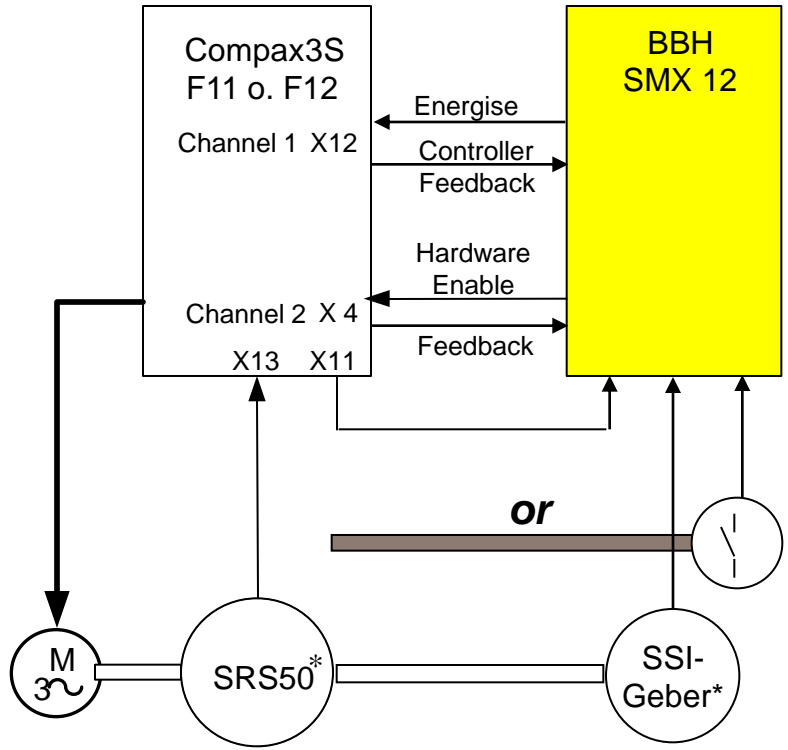

\*or TTL-Encoder

10 - Safely limited position (SLP) only with SSI encoder

- Safely limited position (SLP) only with SSI encoder



## Safe Torque Off (STO)

### Compax3 H:

- no safety function on board!
- Category 3 PL d\* addition function:  
switch off motor cable via external contactor.



\*  $MTTF_d$  care

## Safe Torque Off (STO)

### Compax3 M:

- Certificate EN13849-1.
- Safety Category 3 => PL e with:
  - Safety option S1 and Safety function 
  - Safe Stop 1, (SS1) with external safety module.



## Additional safety function: Category 3 PL d

- Compax3M **F11\*** T30 /T40 + with safety option S3
- no external encoder necessary! 

### additional safety functions

- ◆ Safe Torque Off, STO
- ◆ Safe Stop 1, SS1 (without external safety unit)
- ◆ Safe Stop 2, SS2
- ◆ Safely-limited speed, SLS
- ◆ Safe operating Stop, SOS
- ◆ Safely limited increment, SLI
- ◆ Safe direction, SDI
- ◆ Safe Input/Output Signals

## Additional safety function for Compax3 M with SDC system bus (Safety Drive Core)

Category 3 PL d

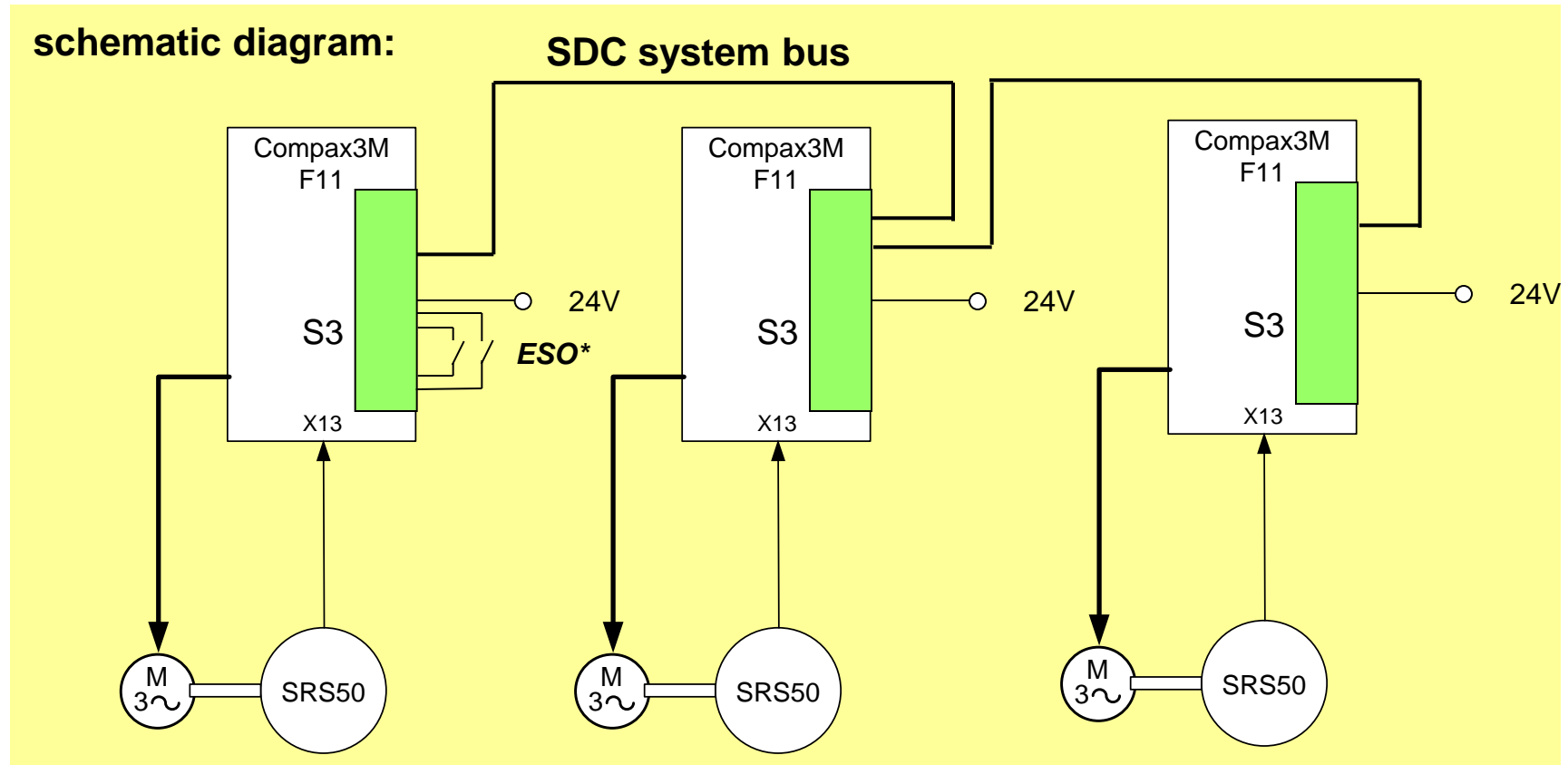

\* ESO = Emergency switch off  
STO / SS1

### Additional safety function: Category 4 PL e

- Compax3M + T30/T40 with safety option S3
- with external encoder\* => X11!



#### additional safety functions

- ◆ Safe Torque Off, STO (Cat. 3 Ple)
- ◆ Safe Stop 1, SS1 (without external safety unit) (Cat. 3 PL e)
- ◆ Safe Stop 2, SS2
- ◆ Safely-limited speed, SLS
- ◆ Safe operating Stop, SOS
- ◆ Safely limited position, SLP\*\*
- ◆ Safely limited increment, SLI
- ◆ Safe direction, SDI
- ◆ Safe Input/Output Signals

\* SSI-encoder or TTL-encoder

\*\* only with SSI Encoder



## Additional safety function

### Category 4 PL e

schematic diagram:

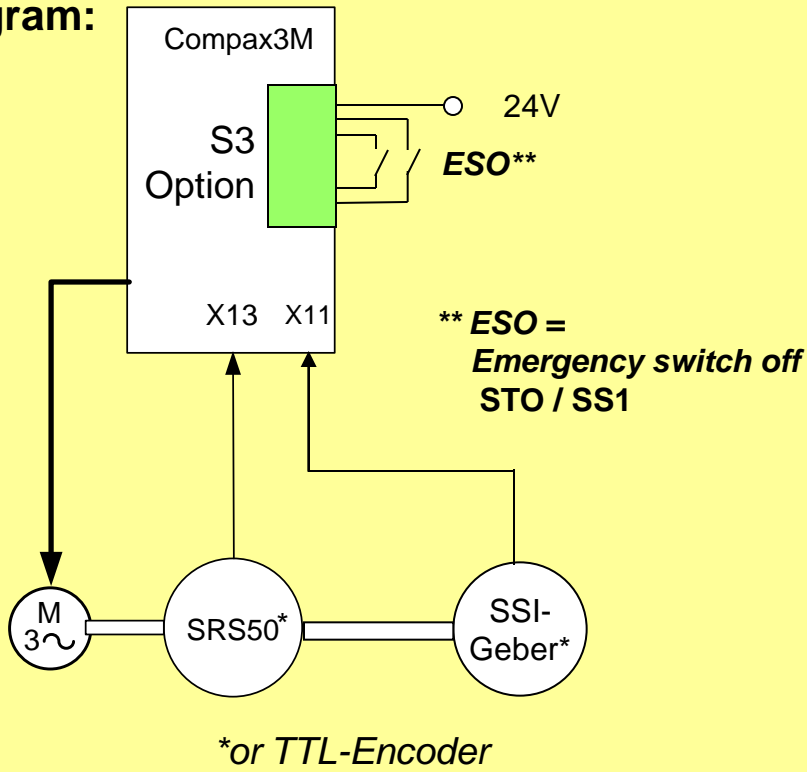

- Sicher begrenzt Position (SLP) nur mit SSI Geber

## Safety according EN 13849-1

Function Drive	cat. 3, PL d		cat. 4, PL e	
	STO	Safety motion	STO	Safety motion
Compax3S	ok	only with additional SMX11 from BBH Products	STO + disconnected motor wires	only with additional SMX12 from BBH Products
Compax3M	only with safety option S1 (PL e)	with safety option S3	only with safety option S3 cat. 3 PL e	with safety option S3
Compax3H	Motor wires must be disconnected with power contactors	-	-	-
SLvD-N	STO (PL e)	-	-	-
TPD-M	ok (1 STO for 3 axes type, 2 STO for 2 axes type)	-	-	-
Hidrive	ok	-	-	-
Twin-N / SPD-N	ok	-	-	-
638 (SSD)	ok	only with additional SMX11 from BBH Products	STO + ext. safety device unit	only with additional SMX12 from BBH Products

 = available

 = available in 2010

***Safety***

***Thank you!***

## Risk Assessment of a machine / system

- Machine manufacturer determines the required Performance Levels ( $PL_r$ )

Risikograph zur Bestimmung des  $PL_r$  für jede Sicherheitsfunktion

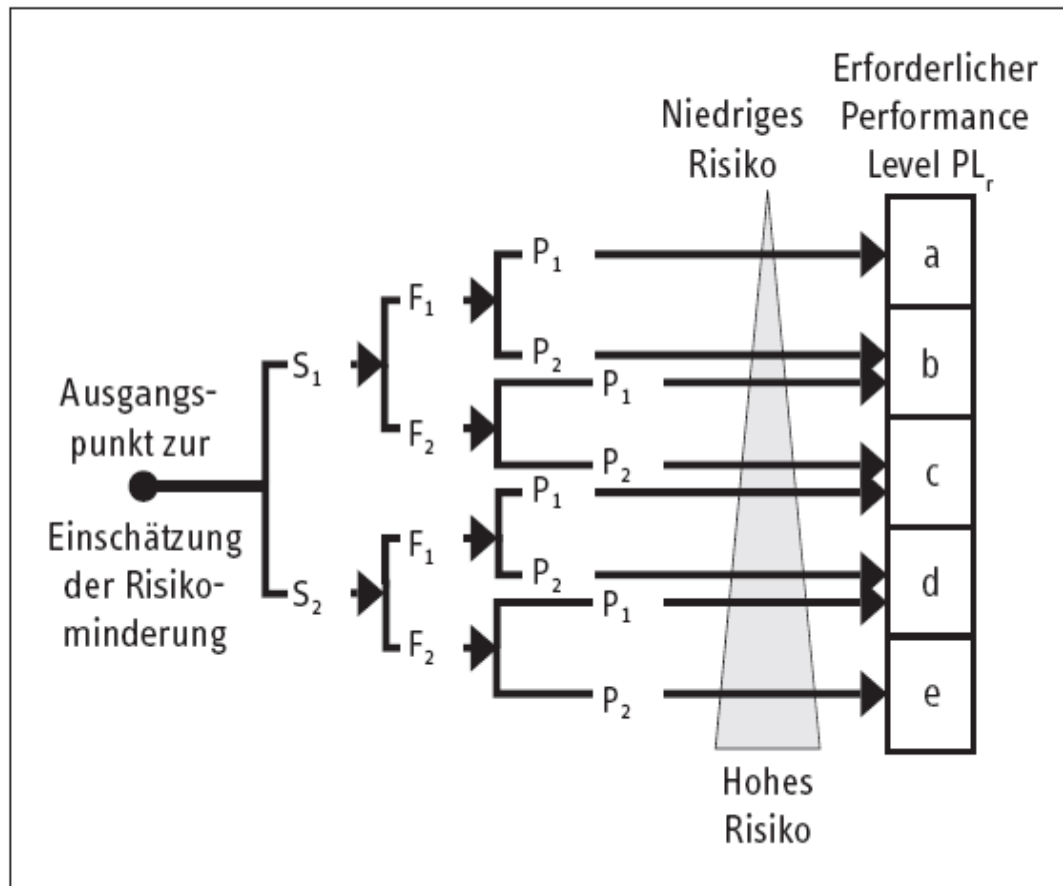

### Risk Parameters:

#### **S Severity of potential Injury**

S1 slight (usually reversible injury)

S2 serious (usually irreversible injury including death)

#### **F Frequency and/or duration of the exposure to hazard**

F1 seldom to not very frequent and/or exposure to hazard is brief

F2 frequent to continuous and/or exposure to hazard is long

#### **P Possibility of preventing the hazard or limiting the harm**

P1 possible under certain conditions

P2 Scarcely possible

#### **Example:**



Determining machine limits:



- Identifying the dangerous machine sections



# Safety

*Example*

Risk parameter based on EN 13849-1



- Work-piece is placed manually.
- Severity of injury
  - 1 -slight (usually reversible injury)
  - 2 -serious (usually irreversible injury including death)

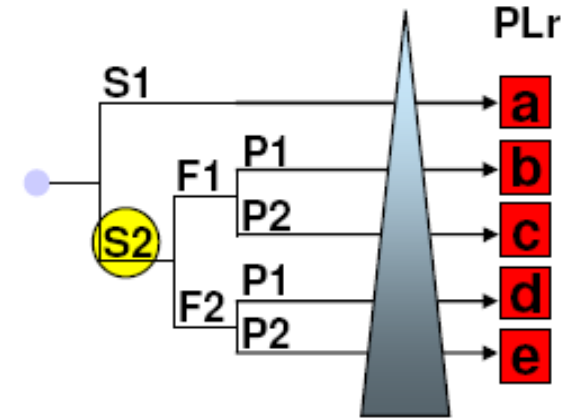

- The rotating part may cause irreversible injury ( i.e. loss of hand)!
- This means choosing parameter **S2**



## Risk parameter based on EN 13849-1



- Work-piece is placed manually.
- Frequency and/or duration of the exposure to hazard:
  - 1 - seldom to not very frequent and/or exposure to hazard is brief
  - 2 - frequent to continuous and/or exposure to hazard is long

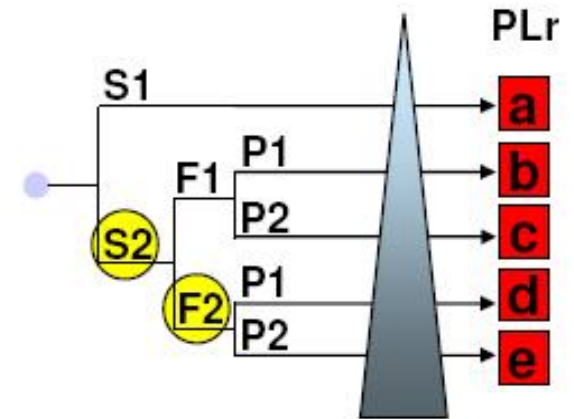

- The work piece is manually placed in the hazardous area after each work cycle. If the safety door is not monitored the danger exists that the work piece is already being placed before the cycle is completed; thus **F2**.
- This means choosing parameter **S2**



### Risikoparameter nach EN 13849-1



- Work-piece is placed manually.
- Possibility of preventing the hazard
  - 1 - possible under certain conditions
  - 2 - Scarcely possible

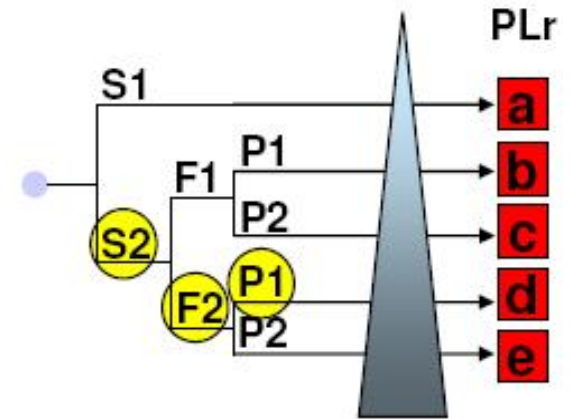

- Danger can be avoided through monitoring of safety door and training of operating personnel.
- This means choosing parameter **P1**





# Safety

## Assigning PL-Factors to Categories

EN ISO 13849-1

Bestimmung des Performance-Levels PL

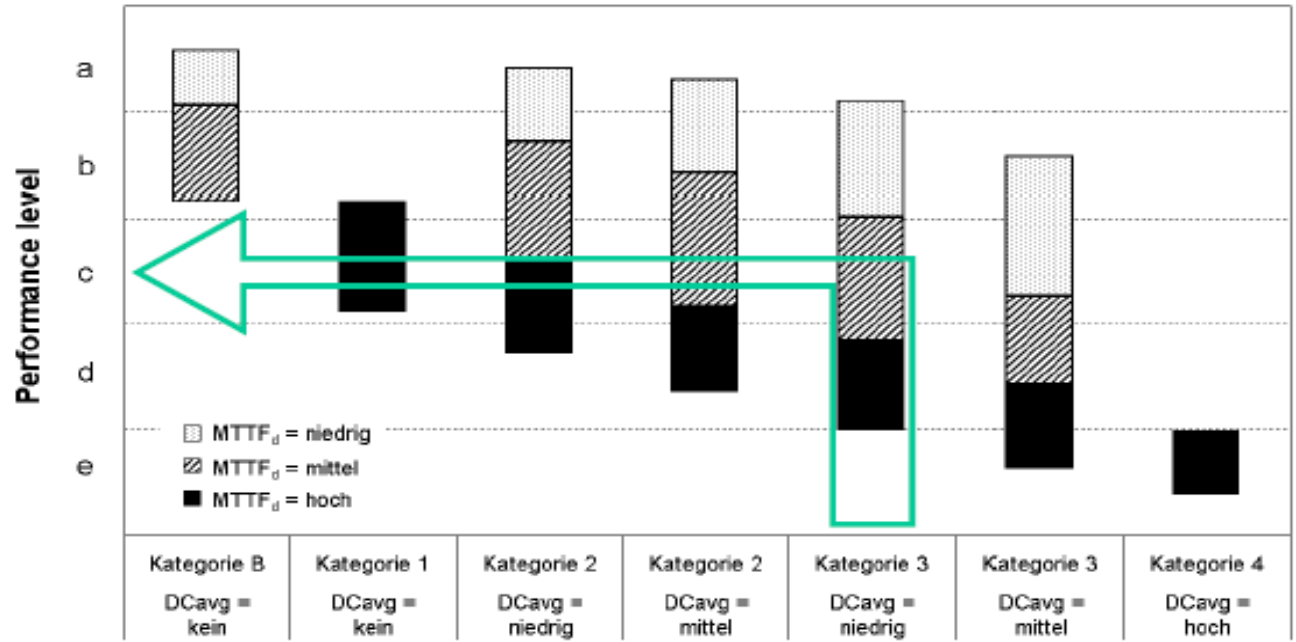

EN954-1 Rev MH © BGIA 05.2005



$MTTF_d$  = mean time to hazardous failure  
 $DC_{avg}$  = mean diagnostic coverage



## MTTF<sub>d</sub> - value

MTTF<sub>d</sub> is the medium time to hazardous failure.

It is based on the fact that every system will eventually fail, if only one waits long enough.

	Bezeichnung	Wertebereich MTTF <sub>d</sub>
	Niedrig	3 Jahre $\leq$ MTTF <sub>d</sub> < 10 Jahre
<i>PL d</i>	Mittel	10 Jahre $\leq$ MTTF <sub>d</sub> < 30 Jahre
<i>PL e</i>	Hoch	30 Jahre $\leq$ MTTF <sub>d</sub> $\leq$ 100 Jahre

## DC - Value

**Diagnostic Coverage** is the partial decrease in probability for hazardous hardware failures, based on the application of automatic diagnostic testing.

*The DC-Value is divided in 4 steps.*

	Bezeichnung	Wertebereich DC
	Kein	DC < 60%
	Niedrig	60% ≤ DC < 90%
PL d	<b>Mittel</b>	<b>90% ≤ DC &lt; 99%</b>
PL e	Hoch	99% ≤ DC

## CCF - Value

### Impact Assessment of Common Cause Failure (CCF)

■ Punktvergabesystem	Soll
■ Physikalische Trennung zwischen Signalpfaden z.B. Trennung der Verdrahtung, Luftstrecken, ..	15
■ Unterschiedliche Technologien, Gestaltung oder physikalischer Prinzipien	20
■ Schutz gegen Überspannung, Überstrom, ..	15
■ „Bewährte Bauteile“	5
■ Ausfallanalyse, Effektanalyse	5
■ geschultes Personal	5
■ System auf EMV-Immunität geprüft	25
■ Umweltbedingungen (Temp., Feuchte, ..)	10
■ Summe:	100

Requirement has been met: Total  $\geq 65$

Total < 65 points = process has failed!

Zuordnung der Ausfallwahrscheinlichkeit zu den Performance Level

Performance Level (PL)	Durchschnittliche Wahrscheinlichkeit eines gefährlichen Ausfalls je Stunde (PFH) in $h^{-1}$
a	$\geq 10^{-5}$ bis $< 10^{-4}$
b	$\geq 3 \cdot 10^{-6}$ bis $< 10^{-5}$
c	$\geq 10^{-6}$ bis $< 3 \cdot 10^{-6}$
d	$\geq 10^{-7}$ bis $< 10^{-6}$ <b>114 bis 1141 Jahre</b>
e	$\geq 10^{-8}$ bis $< 10^{-7}$ <b>1141 bis 11415 Jahre</b>

Safety function use channel1 and channel 2!

„Safe Torque Off (STO) for EN 13849-1 Category 3 PL e possible“

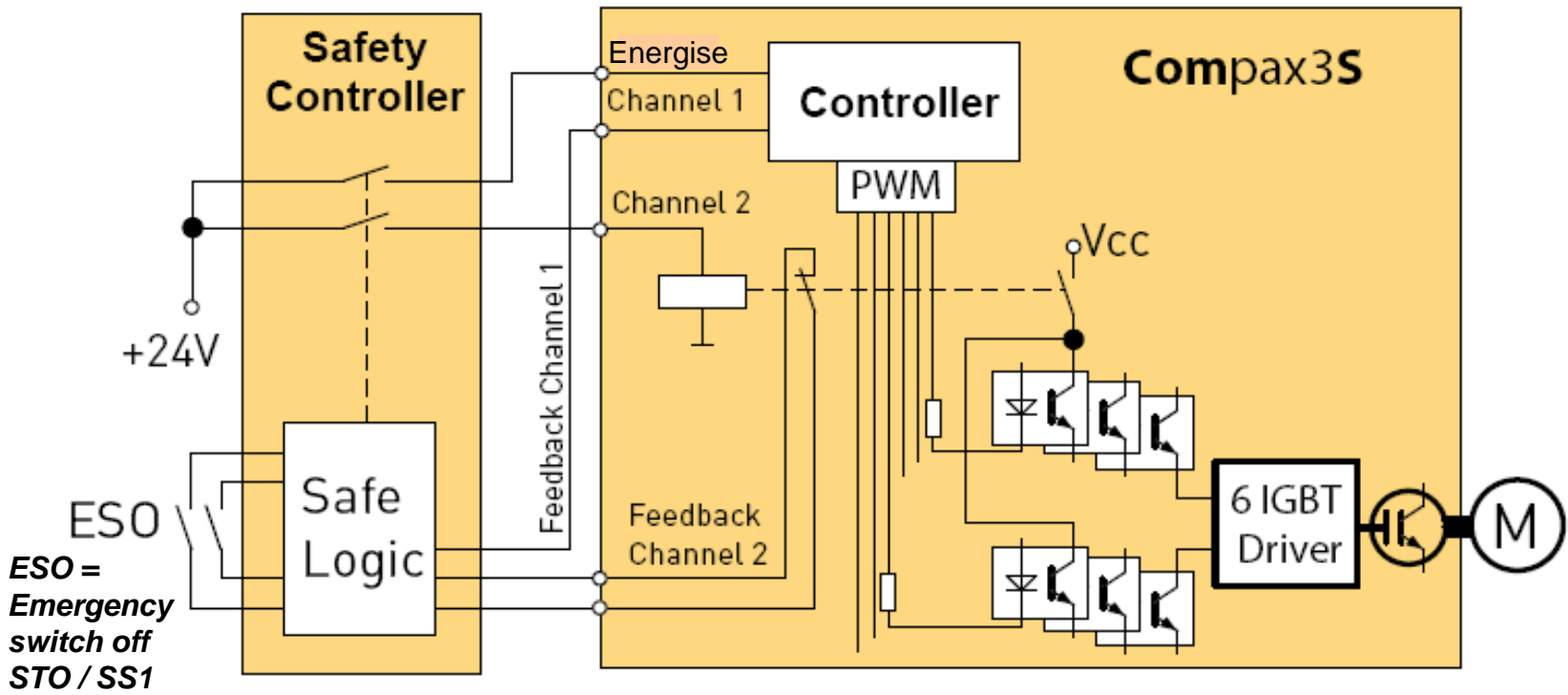

# Safety

## Compax3 S stop category

Stop-Category EN60204-1

Category 3 PL d safety controller SMX11 with one feedback system.

Stop-category 0:  
Safe torque off (STO)

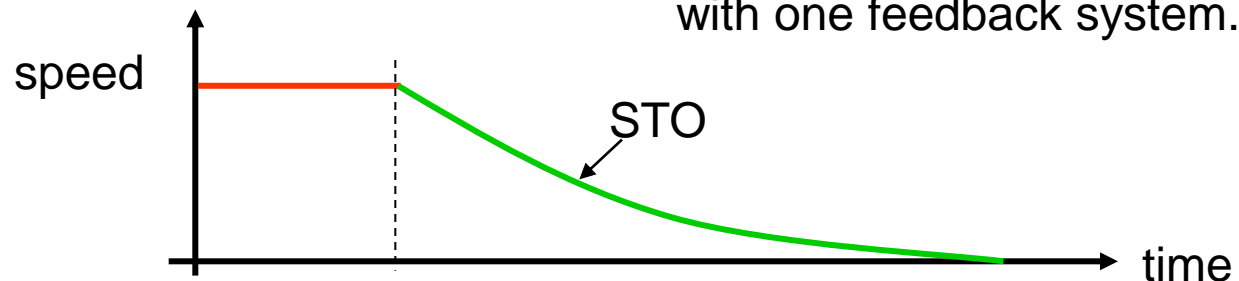

Stop-category 1:  
Safe Stop (SS1)  
controlled standstill

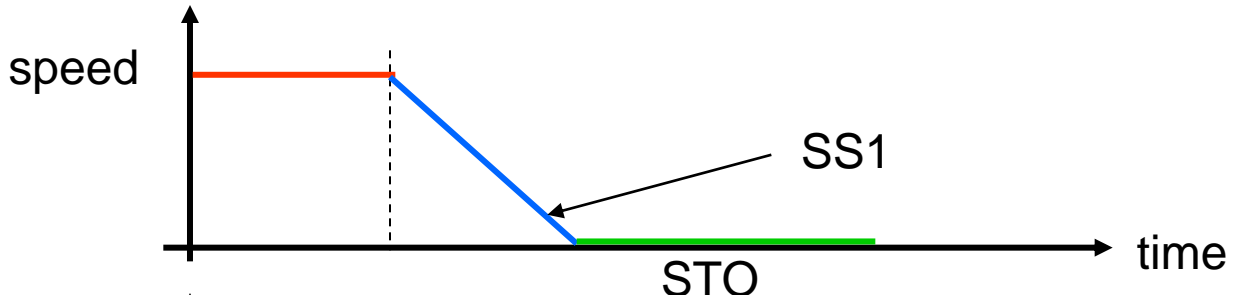

Stop-Categorie 2:  
Safe Stop (SS2)  
controlled standstill

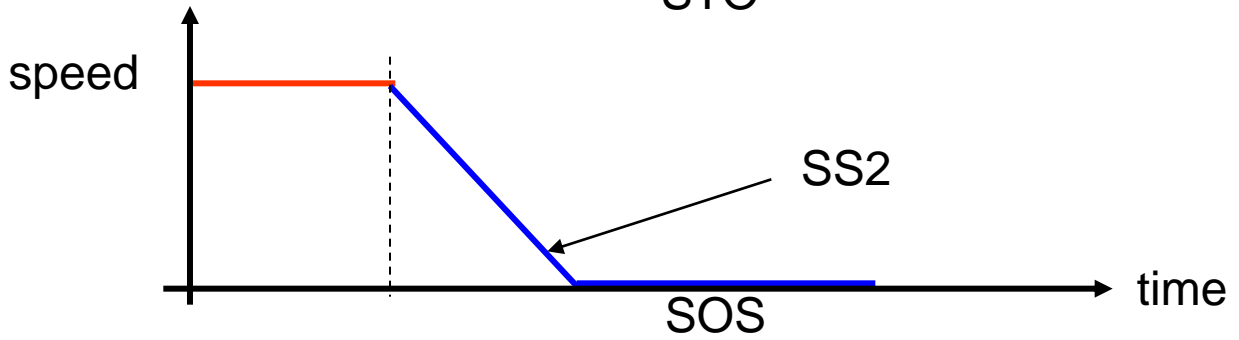

Safe operating stop

# Safety

## Compax3 M with S1 Option

Schematic diagram:

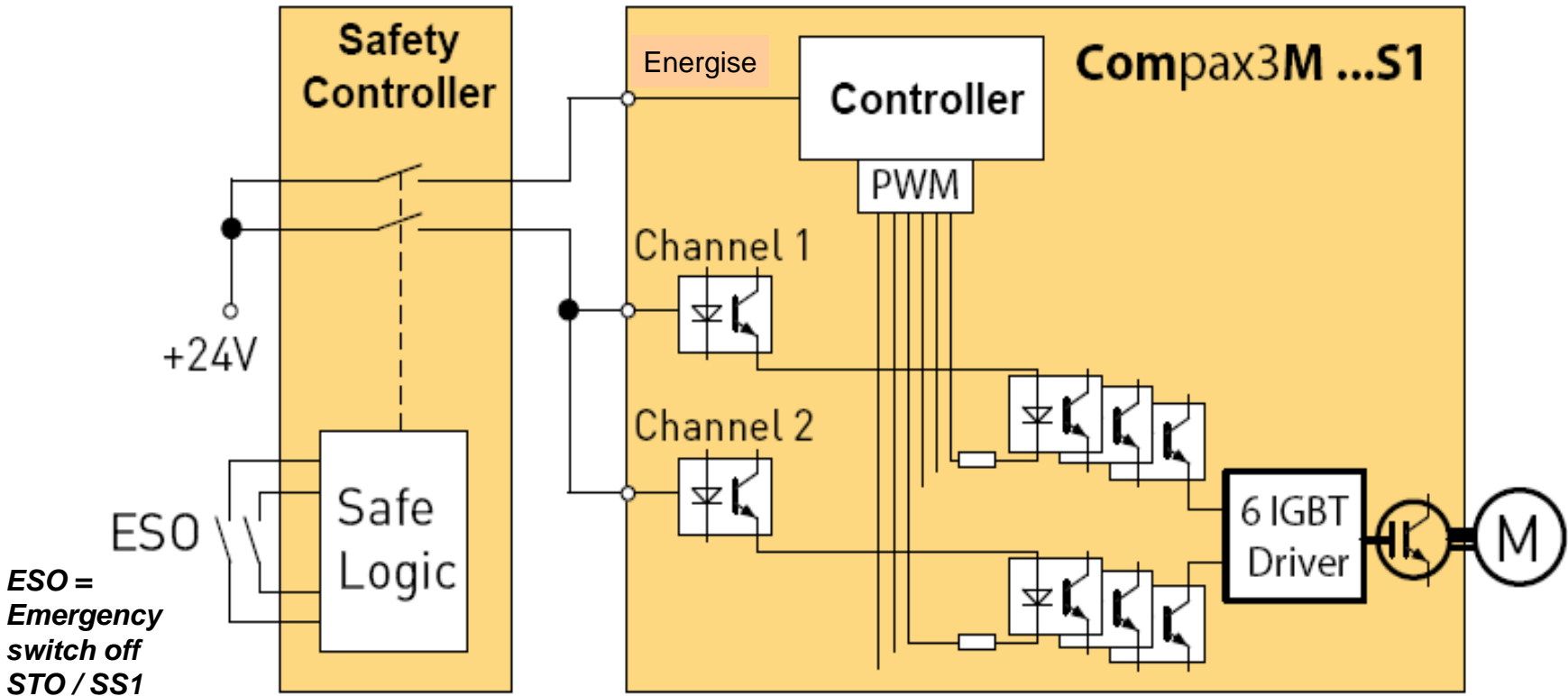

ESO =  
Emergency  
switch off  
STO / SS1

# Safety

# Compax3 M mit S1 Option

## STO-Function with and without external Safety control unit

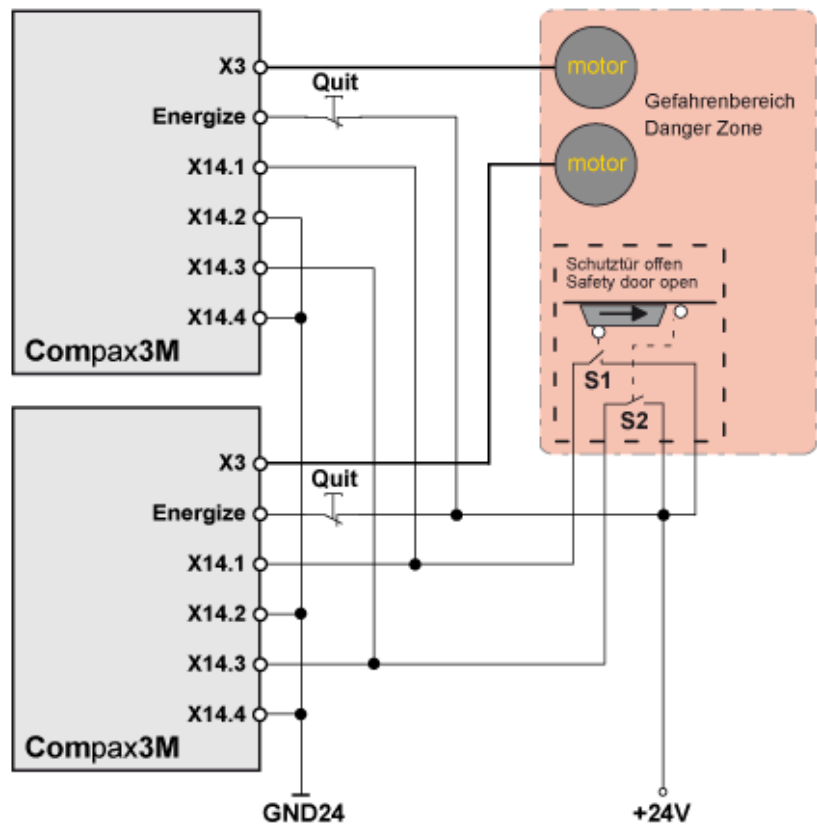

*without external controll unit  
=> STO Function  
Stop-category 0*

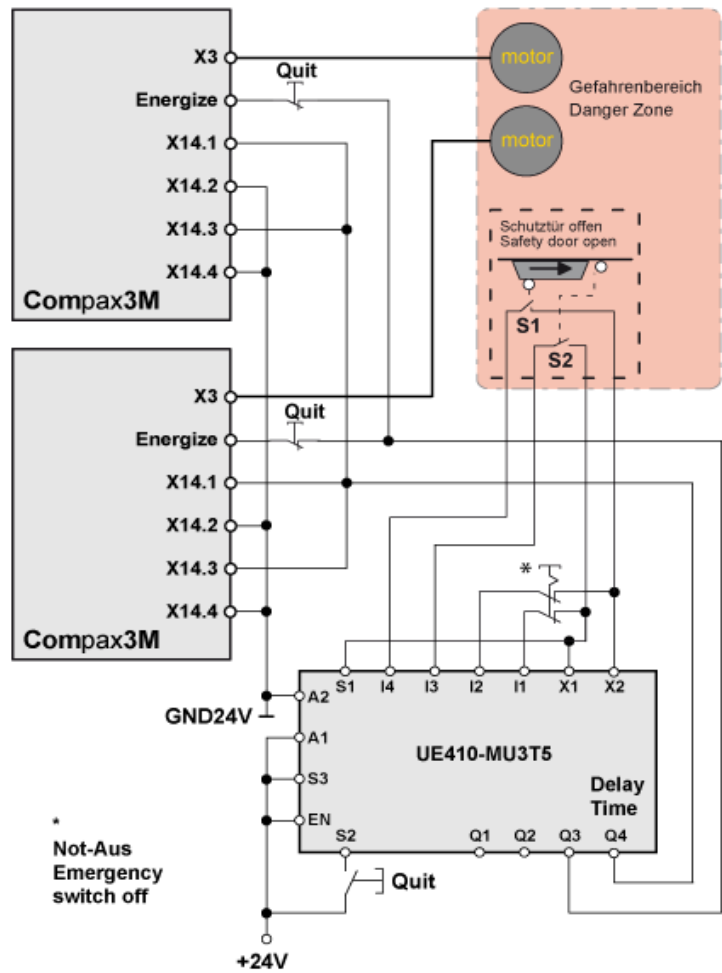

*Stop-Category 1*

Example: Compax 3H with external safe control unit:

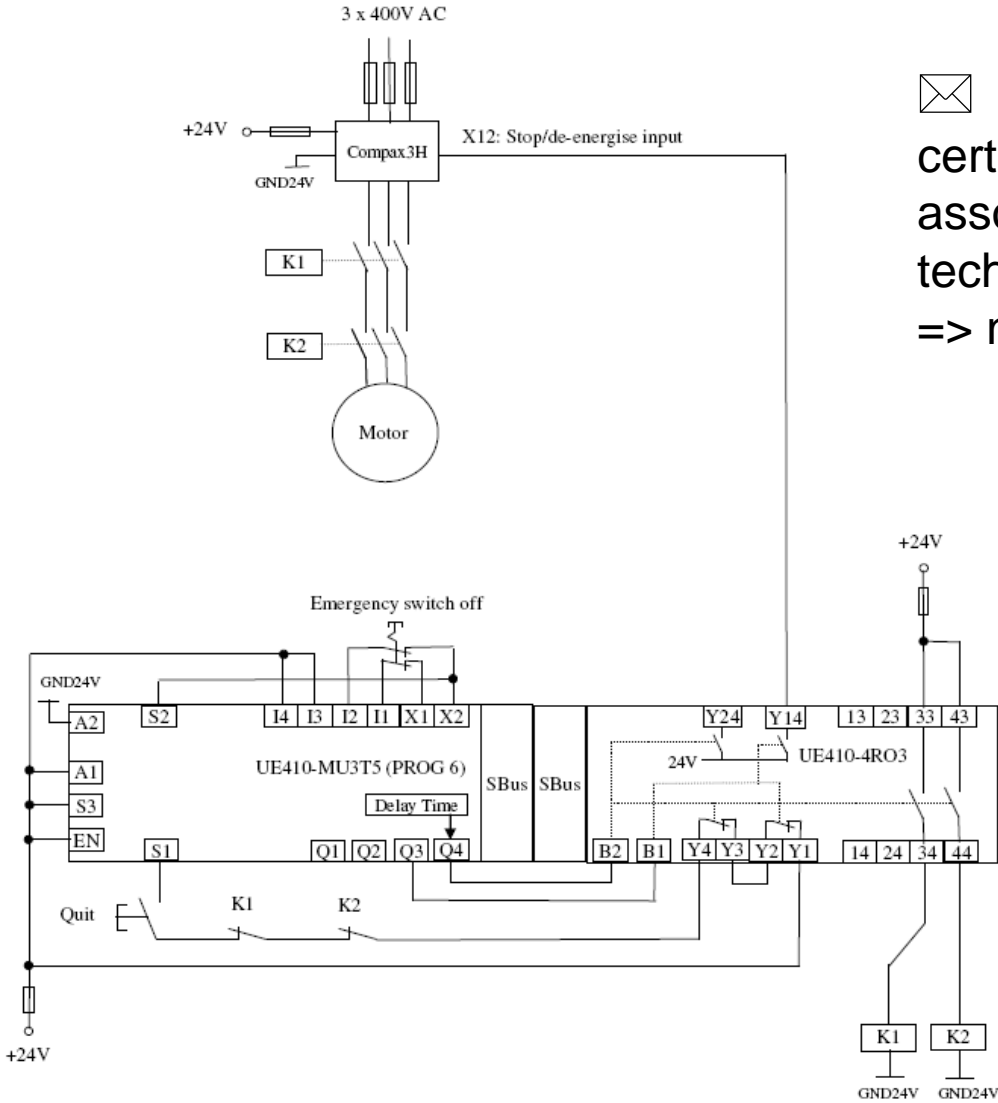

✉ Test via „TÜV“ certified by German association for technical inspection => necessary

Fa. Sick